

Medium Refuse Vehicle (3 axle)
 Overall Length 9.010m
 Overall Width 2.450m
 Overall Body Height 3.742m
 Min Body Ground Clearance 0.295m
 Track Width 2.450m
 Lock-to-lock time 4.00s
 Curb to Curb Turning Radius 8.200m

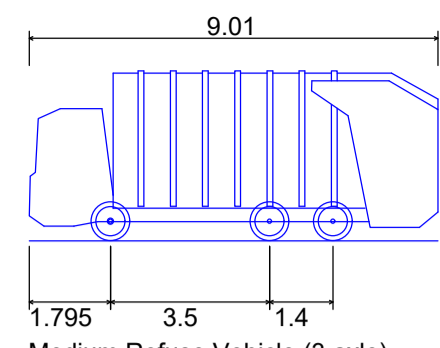

Medium Refuse Vehicle (3 axle)
 Overall Length 9.010m
 Overall Width 2.450m
 Overall Body Height 3.742m
 Min Body Ground Clearance 0.295m
 Track Width 2.450m
 Lock-to-lock time 4.00s
 Curb to Curb Turning Radius 8.200m

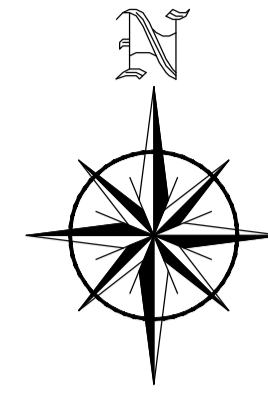

SWEPT PATH ANALYSIS-REFUSE VEHICLE, BASEMENT ACCESS.
 SCALE 1:500

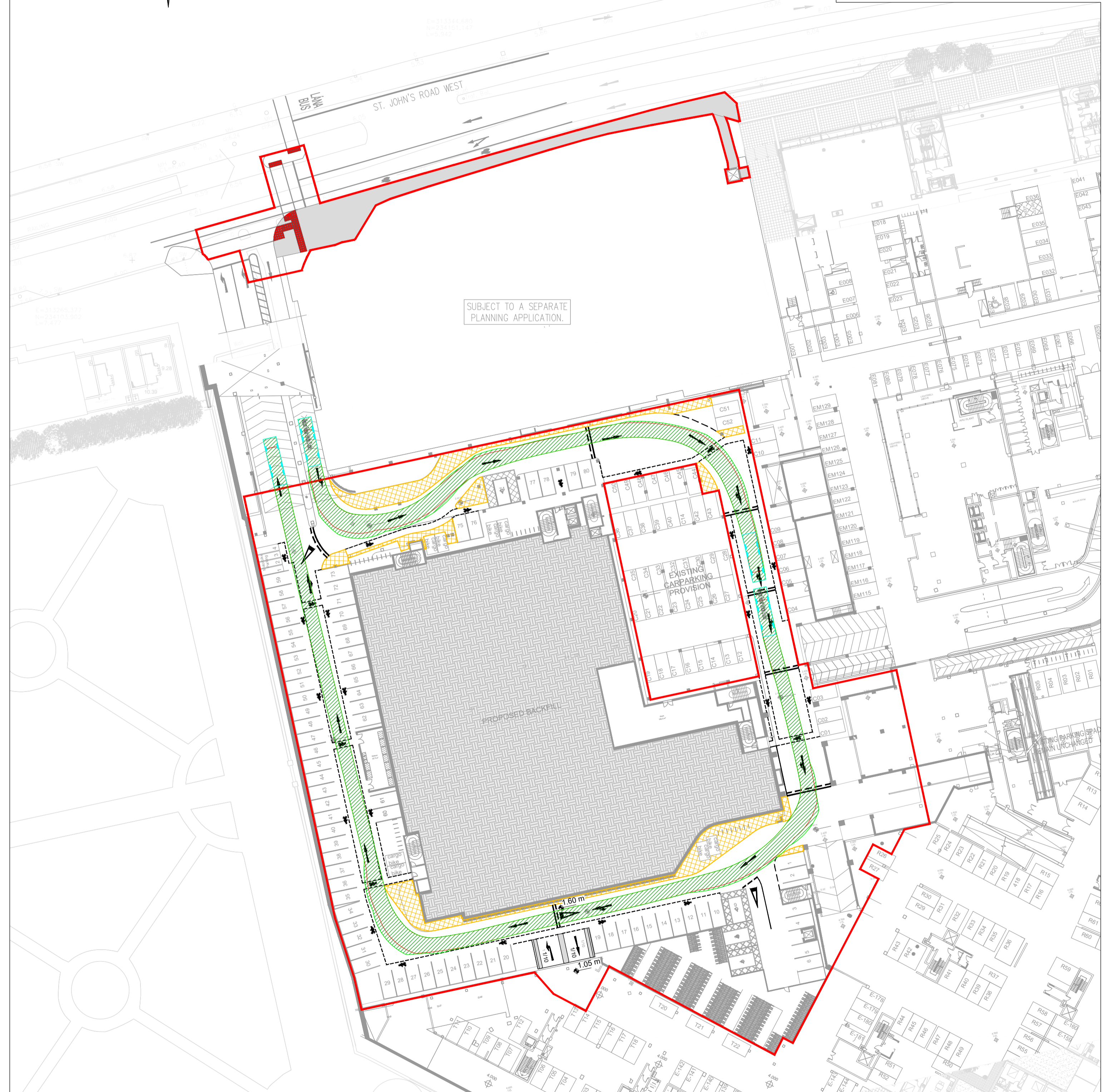

SWEPT PATH ANALYSIS-REFUSE VEHICLE, BASEMENT LEVEL.
 SCALE 1:500

PLANNING DRAWING.
 NOT FOR CONSTRUCTION.
 ALL LEVELS GIVEN ARE
 RELATIVE TO ORDNANCE DATUM.
 THIS DRAWING HAS BEEN ISSUED FOR INFORMATION
 PURPOSES ONLY AND MUST NOT BE USED
 FOR CONSTRUCTION UNDER ANY CIRCUMSTANCES

- NOTES**
- For setting out refer to Architect's drawings.
 - This drawing to be read in conjunction with all other Architectural and Engineering drawings and all other relevant drawings and Specifications.
 - DO NOT SCALE THIS DRAWING. Use figured dimensions only.
 - No part of this document may be reproduced or transmitted in any form or stored in any retrieval system of any nature without the written permission as copyright holder except as agreed for use on the project for which the document was originally issued.
 - Ordnance Survey Ireland Licence Number EN 0074021

Rev. No	Date	REVISION NOTE	Dim. By	Chkd. By
P1	17.09.2021	ISSUED FOR PLANNING STAGE 3	JS	GF

Architect	Reddy Architecture			
Project	HEUSTON SOUTH QUARTER, ST. JOHN'S ROAD WEST, KILMAINHAM			
Title	SWEPT PATH ANALYSIS REFUSE VEHICLE			
Dwg. No.	HSQ-CSC-XX-XX-DR-C-0115			
Date	Dim. by	Chkd. by	Apprv. by	Scale
JULY 2021	JS	NB	DR	1:500 @ A1
				Revision P1

CS Consulting Group
 DUBLIN | LONDON | LIMERICK

Head Office
 19-22 Dame Street, Dublin 2.
 T: +353 (0)1 5480863 F: +353 (0)1 9011355
 e: info@csconsulting.ie
 w: www.csconsulting.ie

Quality Environment Health & Safety
 I.S. EN ISO 9001:2008
 I.S. EN ISO 14001:2004
 I.S. EN ISO 50001:2011
 OHSAS 18001:2007

H087